

Ascensori



Vite di Archimede in FRP. Telaio regolabile, in acciaio zincato o inox. Compreso il tamburo di pesca automatico e la tramoggia di carico, il variatore, il separatore dell'acqua. \approx 400 V/50 Hz~3.

Elevators

Archimedes screw made of FRP. Adjustable frame, galvanized or stainless steel. Including automatic fishing drum and loading hopper, variator, water separator. \approx 400 V/50 Hz~3.

Emelők

Archimedes csavar FRP-ből. Állítható keret, horganyzott vagy rozsdamentes acél. Tartalmazza az automatikus horgászdobot és a betöltő tartályt, variátort, vízleválasztót. \approx 400 V/50 Hz~3.

	Ø (mm)	→ (m)	⇨ max. (m)	 (g)	cap. (t/h)	⚡ (kW)	Υ (kg)
Serie AS / AS-series / AS sorozat							
J004080	380	4	2,0	5 ... 2500	0,5 ... 4	0,7	190
J004082		5	2,7				210
J004084		6	3,4				240
J004086		7	4,0				270



Pompe per pesci

Pompa a propulsore, autoadescante (opzione Milanese SP). Materiale FRP (Pin-Pin, Heathro), alluminio (milanese) o acciaio inossidabile AISI 316 (Pescamotion). Compreso convertitore di frequenza (opzione milanese INV). Controllo remoto opzionale. Azionati con l'energia elettrica (\approx 400 V/50 Hz~3 eccetto se indicato) o con motore (opzione Milanese SB & Heathro) o idraulici (opzione Heathro).

Fish pumps

Propeller pump, self-priming (Milanese option SP). Material FRP (Pin-Pin, Heathro), aluminium (Milanese) or stainless steel AISI 316 (Pescamotion). Including frequency converter (Milanese option INV). Remote control as an option. Electric-driven (\approx 400 V/50 Hz~3 except otherwise indicated) or with engine (Milanese option SB & Heathro) or hydraulic-driven (option Heathro).

Halszivattyúk

Propellers szivattyú, önindító (Milanese opció SP). Anyag FRP (Pin-Pin, Heathro), alumínium (Milanese) vagy rozsdamentes acél AISI 316 (Pescamotion). Tartalmazza a frekvenciaváltót (Milanese INV opció). Távirányító választható. Elektromos meghajtással \approx 400 V / 50 Hz ~ 3, kivéve, ha másképp van feltüntetve) vagy motorral (Milanese SB & Heathro választható) vagy hidraulikus meghajtással (Heathro választható).



	DESCR. / KIJ.	(g)	cap. (t/h)	⇨ (m)	⊕	⚡ (kW)	→↗↘ (mm)	Υ (kg)
Serie Pin-Pin / Pin-Pin series / Pin-Pin sorozat [*]								
J004900	Z-65L-S ~1	0,2 ... 40	4	6	2,5"	1,5	1130 × 550 × 1045	118
J004910	Z-65L-S ~3		2,5"		1,5			
J005002	Z-100L ~1	1 ... 250	8	6	4"	2,2	1400 × 650 × 1200	220
J005000	Z-100L ~3							
J005012	Z-100L-S ~1							
J005010	Z-100L-S ~3							
J005013	Z-150L-S ~1	2 ... 650	15	9	6"	5,5	1705 × 880 × 1575	450
J005014	Z-150L-S ~3							
Serie Milanese / Milanese series / Milanese sorozat [**]								
J004500	185/VS	450	15	2	150	4,0	1250 × 1100 × 1900	345
J004600	185/VCU						1250 × 1100 × 1500	285
J004610	185/VS-SP						1350 × 1100 × 1200	350
J004605	185/VCU-SP						1350 × 1100 × 1200	285
J004700	Maxi/VS	900	30	2	150	4,0	1500 × 1500 × 2100	500
J004710	Maxi/VCU						1500 × 1500 × 1700	400
J004720	Maxi/VS-SP						1600 × 1500 × 2200	500
J004730	Maxi/VCU-SP						1600 × 1500 × 2200	400

continua pagina successiva / to be continued on next page / folytatás a következő oldalon



DESCR. / KIJ.	cap. (g)	cap. (t/h)	h (m)	φ	↗ (kW)	→↑↑ (mm)	Υ (kg)	
Serie Pescamotion / Pescamotion-series / Pescamotion sorozat								
J004810 PH-10	40	4	12	2"½	1,1	995 × 645 × 1049	90	
J004820 PH-30	700	20		6"	3		1760 × 860 × 1060	202
J004821					5,5			212
J004827	Separatore d'acqua 6" / Water separator 6" / Víz elválasztó 6"							
J004830 PH-40	1500	40	15	8"	11	1740 × 1080 × 1640	602	
J004837	Separatore d'acqua 8" / Water separator 8" / Víz elválasztó 8"							
J004840 PH-50	3000	50	10	10"	18,5	1597 × 1300 × 1923	950	
J004847	Separatore d'acqua 10" / Water separator 10" / Víz elválasztó 10"							
J004849	Telecomando / Remote control / Távirányító [∅]							
Serie Heathro / Heatro-series / Heathro sorozat [***]								
J004860 HFP 6 ~3	0,2 - 400	10	5	6"	5,5	1700 × 810 × 1190	200	
J004870 HFP 6					5 HP			
J004880 HFP 8 ~3	0 - 1200	60	9	8"	14,7	2030 × 1320 × 1520	730	
J004890 HFP 8					20 HP			
J004895	Telecomando / Remote control / Távirányító							

[*] -S: versione per acqua di mare / seawater version / tengervízi verzió

[**] S: separatore d'acqua / water separator / víz elválasztó - CU: gomito / elbow / könyök
SP: autoadescante / self-priming / önindító

[***] modello subacqueo disponibile su richiesta / submersible model available on request /
merülő modell megrendelésre kapható

[∅] tutti i modelli Pescamotion (200 m) / all Pescamotion models (200 m)
minden Pescamotion modell (200 m)

Disponibile anche / Also available / Szintén kapható : Aqua-Life 6-8-10-12-17", KSF, ...

Pompe a vuoto per pesci

Due cilindri 150-200 litri risucchi (max. 5 m) pesce in alternativa. Telaio in acciaio galvanizzato o inox (standard Pescavac ; opzione Milanese), con altezza regolabile come opzione (Milanese REG). Compreso il separatore dell'acqua. Scala di pesatura integrata (Milanese BS) o unità indipendente (↗ AquaMASS pagina 88). φ 5-6" (Pescavac 8" & 10"); ↗ 400 V/50 Hz~3.

Vacuum fish pumps

Two cylinders 150-200 liters suck (max. 5 m) fish alternatively. Galvanized steel frame or stainless steel (Pescavac standard ; Milanese option), with adjustable height as an option (Milanese REG). Including water separator. Weighing scale integrated (Milanese BS) or independent unit (↗ AquaMASS page 88). φ 5-6" (Pescavac 8" & 10"); ↗ 400 V/50 Hz~3.

Vákuumos halszivattyúk

Két henger, 150-200 liter, szívja (max. 5 m) a halakat. Galvanizált acélkeret vagy rozsdamentes (alapértelmezett Pescavac ; választható Milanese), opcionálisan állítható magassággal (milánói REG). Tartalmazza a vízválasztót. Integrált mérleg (milánói BS) vagy független egység (↗ AquaMASS 88. oldal). φ 5-6" (Pescavac 8" & 10"); ↗ 400 V/50 Hz~3.

DESCR. / KIJ.	cap. (g)	cap. (t/h)	h (m)	↗ (kW)	→↑↑ (mm)	Υ (kg)	
Serie Milanese / Milanese series / Milanese sorozat							
J005100 185/VAC-1	1500	15	1,75	5,6	2900 × 1450 × 3150	775	
J005200 185/VAC-2	3000			9			
J005210 185/VAC-1 REG	1500			1,35	1650 × 4300 × 3400	1550	
J005220 185/VAC-2 REG	3000			3,05			
J005230 185/VAC-1 BS	1500			-	12	2600 × 1400 × 4800	1800
J005240 185/VAC-2 BS	3000						
Serie Bluecomfort / Bluecomfort series / Bluecomfort sorozat							
J005300 P16	5000	16	0,9... 1,5	4	3600 × 1550 × 2300	650	
Serie Pescavac / Pescavac series / Pescavac sorozat							
J005310 PV-50 (8")	3500	8	5	5,3	2600 × 1200 × 1500	440	
J005320	Separatore d'acqua 8" / Water separator 8" / Víz elválasztó 8"						
J005310 PV-60 (10")	4500	12	5	11	2900 × 1540 × 2075	750	
J005320	Separatore d'acqua 10" / Water separator 10" / Víz elválasztó 10"						

Classificatori manuali

Griglie di scarpata a scambio rapido (SCU con griglia fissa), con tubo rotondo (SH) con spaziatura fissa. Versione standard o flottante. Anche su richiesta : FRP serbatoio rettangolare per 3 o 4 scatole di classificazione SB, scatola e griglie DATI...

Manual graders

Quick-exchanging grading grids (except SCU with fixed grid), with round tube (SH) with fixed spacing. Standard version or floating version. Also available on request : FRP rectangular tank for 3 or 4 grading boxes SB, box and grids DATI...

Kézi gyalu

Gyorsan cserélhető gyalurácsok (SCU: rögzített rácsos), kerek csővel (SH), rögzített távolsággal. Normál vagy lebegő verzió. Igény szerint is kapható: FRP téglalap alakú tartály 3 vagy 4 SB osztályozó dobozhoz, dobozhoz és DATI rácsokhoz...

📖	DESCR. / KUJ.	Mat.	↗↗↗ (mm)
Scatola di classificazione standard / Standard grading box / Szabványos gyaludoboz			
J005800	SB [*]	PRFV / FRP	700 × 540 × 340
J005790	FIAP		645 × 500 × 430
J005780	SH		460 × 460 × 160
Scatola di classificazione galleggiante / Floating grading box / Lebegő gyaludoboz			
J005795	SB	PRFV / FRP	700 × 540 × 340
J005910	PFB	legno / wood / faip.	550 × 340 × 110
J005715	SCU (2 - 3 - 4 - 5 mm)	plastic. / műanyag	450 × 300 × 150

📖	📏 (mm)	📖	📏 (mm)	📖	📏 (mm)	📖	📏 (mm)	📖	📏 (mm)
Griglia curva SB (PVC) / SB curved grid (PVC) / Ívelt rács SB (PVC) [**]									
J005801	3	J005836	6,5	J005813	13	J005820	20	J005827	27
J005802	3,5	J005807	7	J005814	14	J005821	21	J005828	28
J005803	4	J005808	8	J005815	15	J005822	22	J005829	29
J005804	4,5	J005809	9	J005816	16	J005823	23	J005830	30
J005805	5	J005810	10	J005817	17	J005824	24	-	-
J005835	5,5	J005811	11	J005818	18	J005825	25	-	-
J005806	6	J005812	12	J005919	19	J005826	26	-	-
Griglia plana FIAP (alu.) / FIAP flat grid (alu.) / Rács lemez FIAP (alu.)									
J005887	3	J005859	9	J005865	15	J005872	22	J005878	28
J005889	4	J005860	10	J005867	17	J005873	23	J005879	29
J005891	5	J005861	11	J005868	18	J005874	24	J005880	30
J005856	6	J005862	12	J005869	19	J005875	25	J005881	31
J005857	7	J005863	13	J005870	20	J005876	26	J005885	35
J005858	8	J005864	14	J005871	21	J005877	27	-	-
Griglia plana SH / SH flat grid / Rács lemez SH [plexiglas 190 × 205 mm]									
J005930	2	J005932	3	J005934	4	J005936	5	-	-
J005931	2,5	J005933	3,5	J005935	4,5	-	-	-	-
Griglia plana PFB (alu.) / PFB flat grid (alu.) / Rács lemez PFB (alu.)									
J005911	2	J005914	3,5	J005917	5	J005920	8	-	-
J005912	2,5	J005915	4	J005918	6	J005921	9	-	-
J005913	3	J005916	4,5	J005919	7	J005922	10	-	-

Classificatori manuali regolabili

Galleggiante (tranne SCA). Telaio legno impregnato (HG) o alluminio (MG, SCA).

Adjustable manual graders

Floating (except SCA). Impregnated wood (HG) or aluminium (MG, SCA) frame.

Állítható kézigyalu

Lebegő (az SCA kivételével). Impregnált fa (HG) vagy alumínium (MG, SCA) keret.

📖	DESCR.	📏 (mm)	■ ■ ■	↗↗↗ (mm)	⚖ (kg)
J005600	HG-1	4 ... 17	14	360 × 360 × 180	3,0
J005700	HG-2	18 ... 30	13	440 × 460 × 180	4,0
J005710	MG-1	6,4 ... 29	30	432 × 381 × 190	7,7
J005711	MG-2	4,0 ... 35	50	711 × 533 × 279	16
J005713	SCA	2,0 ... 20	19	460 × 300 × 250	5

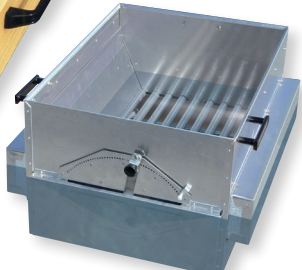
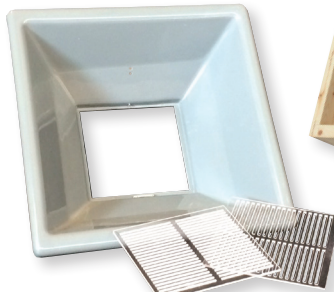
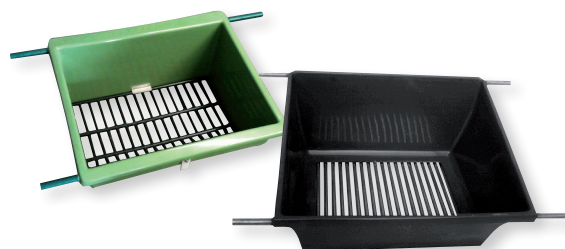

☞ smistatori delle uova pagina 29 / egg sorters page 29 / tojásválogató 29. oldal

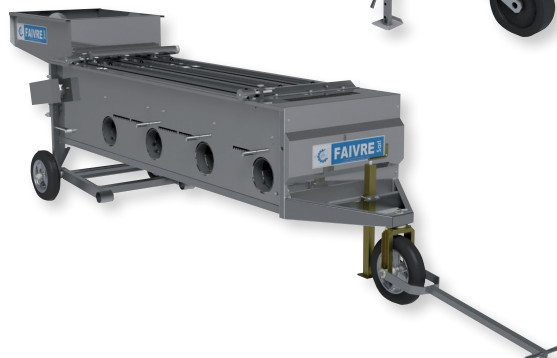
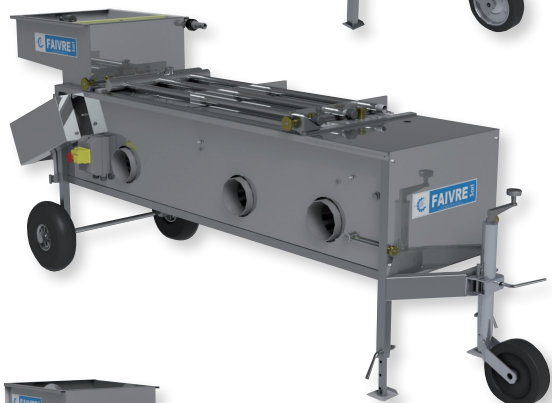

Classificatori semiautomatici

Guarnizione a rulli con nonio di regolazione della spaziatura (STM) o multi-box (SK). Materiali FRP e rulli in acciaio inox. Compresa imbocco per l'acqua e le tubazioni ; pompa su richiesta. STM : altezza e pendenza regolabili.

Semi-automatic graders

Roller grader with spacing adjustment vernier (STM) or multi-box (SK). Materials FRP and stainless steel rollers. Including water inlet and piping ; pump on request. STM : adjustable height and slope.

Félautomata gyalu

Hengergyalu távolság-finombeállító (STM) vagy multi-box (SK). Anyagok FRP és rozsdamentes acél görgők. Tartalmazza a vízbevezetést és a csöveket; szivattyú megrendelésre. STM: állítható magasság és lejtő.

DESCR.	(g)	Q (L/s)	→↑↑ (mm)	Υ (kg)
J006005	10 ... 200	2	2400 × 700 × 1100	62
J006100	10 ... 450	2	1680 × 9850 × 850	60
J006105		3	1900 × 1050 × 1300	90

Kit distanziatore SK / SK Spacer kit / SK távtartó készlet

(mm)	(mm)	(mm)	(mm)	(mm)	(mm)
J006406	J006410	J006418	J006426	J006428	J006430
6	10	18	26	28	30
J006407	J006412	J006420	J006422	J006435	
7	12	20	22	35	
J006408	J006414	J006424			
8	14	24			
J006409	J006416				
9	16				

Classificatori automatici SPS

Realizzato in acciaio inossidabile AISI 304 / 316. tecnologia SPS (stecche di trasporto). Nonio di regolazione ad alta precisione. Spruzzo d'acqua di pesce durante la classificazione. Prese multidirezionali. Altezza regolabile con jack di sollevamento. Sistema a cinghia. Tramoggia di separazione dell'acqua integrata. ~ 400 V/50 Hz~3 (opzione 230 V/50 Hz~1).

SPS automatic graders

Made of stainless steel AISI 304 / 316. SPS technology (conveying slats). High precision adjustment vernier. Fish water spray during grading. Multi-directional outlets. Adjustable height with lifting jack. Belt-driven system. Water separating hopper integrated. ~ 400 V/50 Hz~3 (option 230 V/50 Hz~1).

SPS automatikus gyalu

Rozsdamentes acélból készült AISI 304 / 316. SPS technológia (lécek szállítása). Nagy pontosságú beállító finomhangoló. Halvíz permetezés gyalulás közben. Többirányú aljzatok. Állítható magasság emelőkosárral. Szívvezérelt rendszer. Integrált vízleválasztó garat. ~ 400 V / 50 Hz ~ 3 (opció 230 V / 50 Hz ~ 1).

DESCR.	(g)	cap. (t/h)	Q (m ³ /h)	(kW)	→↑↑ (mm)	Υ (kg)
J007290	1 ... 120	4 (5 c.)	0,3	20	3400 × 1140 × 1340	280
J007280		4 (8 c.)	0,5		3650 × 1600 × 1340	520
J007520	5 ... 350	3 (2 c.)	4	0,25	3000 × 920 × 1100	210
J007550		3 (3 c.)			4050 × 1010 × 1375	430
J007560	5 ... 800	4 (5 c.)	6	0,37	4375 × 1400 × 1530	620
J007800		4 (3 c.)			4500 × 1175 × 1430	480
J008020	5 ... 1500	4 (5 c.)	6	0,55	4750 × 1730 × 1490	520
J008100		3 (3 c.)			50	4760 × 1250 × 1650
J008150	50 ... 2500	3 (5 c.)	9	0,55	5200 × 1800 × 1950	1045
J008200		3 (2 c.)			50	3565 × 1235 × 1675
J008250	250 ... 3500	3 (3 c.)	8	0,55	4745 × 4675 × 1635	660

disponibili su richiesta: pompa acqua sommersibile e tubo a spirale 5 m Ø 50 mm, contatori integrati (modelli 40 e 50), spazzole per pesci delicati (modelli 10), attacco pompa pesce, quadro elettrico multicontrol (pompa pesce, contatori, selezionatore, pompa dell'acqua)... available on request : submersible water pump & spiral hose 5 m Ø 50 mm, integrated counters (models 40 & 50), brushes for delicate fish (models 10), fish pump connection, electric cabinet multi-control (fish pump, counters, sorter, water pump)...

kérésre: merülő vízszivattyú és spiráltömlő 5 m Ø 50 mm, beépített pultok (40-es és 50-es modellek), kefék kényes halakhoz (10-es modellek), halpumpa csatlakozó, elektromos szekrény többfunkciós vezérlés (halpumpa, pultok, válogató), vízszivattyú)...

Classificatori automatici a rullo

Materiale FRP (AFGM) o acciaio inossidabile AISI 316 (Apollo). Basato su rulli rotanti con spaziatura crescente. Opzioni separatore dell'acqua (Apollo). \approx 230 V/50 Hz~1 o 400 V/50 Hz~3.

Automatic roller graders

Material FRP (AFGM) or stainless steel AISI 316 (Apollo). Based on rotating rollers with increasing spacing. Option water separator (Apollo). \approx 230 V/50 Hz~1 or 400 V/50 Hz~3.

Automatikus hengergyalu

Anyag FRP (AFGM) vagy rozsdamentes acél AISI 316 (Apollo). A növekvő távolságú forgó görgők alapján. Opciók: vízleválasztó (Apollo). \approx 230 V/50 Hz~1 vagy 400 V/50 Hz~3.

DESCR.	(g)	cap. (t/h)	Q (m ³ /h)	\approx (kW)	$\rightarrow \nearrow \uparrow$ (mm)	Υ (kg)		
Serie AFGM / AFGM series / AFGM sorozat								
J006450	A-3	10 ... 600	3 (3 c.)	4	18	0,25	3200 x 1000 x 1200	170
J006460	A-5		3 (5 c.)	6	25		3300 x 1550 x 1300	390
J006470	A-6		3 (6 c.)	8	36	0,35	3400 x 1780 x 1350	460
Serie Apollo / Apollo series / Apollo sorozat								
J009000	43-A	1 ... 650	3 (4 c.)	3	1,0	0,18	3150 x 1080 x 1280	280
J009002	44-A		4 (4 c.)					
J009004	53-A		3 (5 c.)					
J009006	54-B	5 ... 750	4 (5 c.)	4	1,0	0,18	3150 x 1280 x 1280	375
J009008	53-B		3 (5 c.)					
J009010	54-B	4 (5 c.)	5,5	1,4	0,18	3150 x 1660 x 1280	485	
J009014	73-A	3 (7 c.)						
J009016	74-A	4 (7 c.)						
J009018	73-B	5 ... 750	3 (7 c.)	8	2,0	0,18	3500 x 2220 x 1280	650
J009020	74-B		4 (7 c.)					
J009022	103-A	1 ... 650	3 (10 c.)	8	2,0	0,18	3500 x 2220 x 1280	650
J009024	104-A		4 (10 c.)					
J009026	103-B	5 ... 750	3 (10 c.)	8	2,0	0,18	3500 x 2220 x 1280	650
J009028	104-B		4 (10 c.)					

disponibili su richiesta: livellatrici a nastro Fischtechnik FGM, gamma di livellatrici a rulli Milanese, livellatrici Vaki Smart, livellatrici a nastro Melbu, ...
available on request: Fischtechnik FGM belt graders, Milanese roller graders range, Vaki Smart graders, Melbu belt graders, ...
kérésre kapható: Fischtechnik FGM szalagos gréderek, milánói görgős gréderek, Vaki Smart gréderek, Melbu szalagos gréderek, ...

Classificatori automatici di tamburi

Tamburo rotante (0...10 giri/min) formato da tondini Ø 16 mm equispaziati che formano un cono. Il pesce viene pompato dall'estremità stretta del cono verso il lato interno. Un flusso continuo d'acqua spinge dolcemente il pesce lungo le aste e quando lo spazio tra le aste è uguale allo spessore del pesce cade attraverso e nello scivolo di uscita. Acciaio inossidabile AISI 316. \approx 230 V/50 Hz~1.

Automatic drum grader

Rotary drum (0 ... 10 rpm) formed of equally spaced Ø 16 mm rods that make up a cone. The fish is pumped in on the narrow end of the cone to the internal side. A continuous flow of water gently pushes the fish down along the rods and when the space between to rods is equal to the fish thickness it falls through and into the outlet chute. Stainless steel AISI 316. \approx 230 V/50 Hz~1.

Seleccionadora automática de tambor

Forgódob (0 ... 10 ford./perc), egyenlő távolságban elhelyezett Ø 16 mm-es rudakból, amelyek kúpot alkotnak. A halat a kúp keskeny végén a belső oldalra pumpálják. A folyamatos vízáramlás finoman lenyomja a halat a botok mentén, és amikor a botok közötti távolság megegyezik a hal vastagságával, átesik a kifolyó csúszdán. Rozsdamentes acél AISI 316. \approx 230 V/50 Hz~1.

DESCR.	(g)	(mm)	cap. (t/h)	\approx (kW)	$\rightarrow \nearrow \uparrow$ (mm)	Υ (kg)	
J009050	I	> 0,5	4 / 8 / 12	3	0,37	1800 x 845 x 1900	25
J009051	II		9 / 14 / 19				
J009052	III		20 / 28 / 35				





Classificatore rotante

Materiale in acciaio inox e plastica. Il grader circolare ha un numero di scatole (lunghezza 220 o 500 mm) che ruotano all'interno del dispositivo. Dato che ogni scatola passa sopra una presa lo spazio di scarpata nella parte inferiore della scatola viene automaticamente aumentato a una dimensione preimpostata (0 ... 50 mm). Rotazione 5 ... 15 giri/min. ~ 230 V/50 Hz~1.

Revolving grader

Material stainless steel and plastic. The circular grader has a number of boxes (220 or 500 mm length) that rotate within the device. As each box passes over an outlet the grading gap in the bottom of the box is automatically increased to a pre-selected size (0 ... 50 mm). Rotation 5 ... 15 rpm. ~ 230 V/50 Hz~1.

Gördülő gyalu

Anyag: rozsdamentes acél és műanyag. A körkörös gyalunak számos doboza van (220 vagy 500 mm hosszú), amelyek az eszközön belül forognak. Amint minden doboz áthalad egy kimeneten, a doboz alján lévő gyalurést automatikusan növeli egy előre kiválasztott méretre (0 ... 50mm). 5-15 fordulat / perc. ~ 230 V/50 Hz~1.

Icon	DESCR.	Icon (g)	Icon (4)	cap. (t/h)	Q (m ³ /h)	Icon (kW)	Ø × ↑ (mm)	Y (kg)
J007010	K-96	0,2 ... 100	4	1	3,6	0,37	1000 × 1200	150



Griglie stagno

Griglie in alluminio con profilo speciale, come la forma di un'ala aeroplano, per un flusso ottimale dell'acqua senza perdita di carica aggiunta e per evitare lesioni ai pesci. Il telaio superiore è progettato per una facile pulizia della griglia. Spessore 40 mm. Dimensioni (lunghezza e altezza) in base alle esigenze del cliente.

Pond grids

Aluminium grids with special profile, like the shape of an aeroplane wing, for optimum water flow without additional loss of charge, and in order to avoid fish injuries. Top frame is designed for easy grid cleaning. Thickness 40 mm. Dimensions (length and height) according to customer needs.

Tavi rácsok

Különleges profilú alumínium rácsok, például a repülőgépszárny alakú, az optimális vízáramlás érdekében, további töltésvesztés nélkül, valamint a hal sérüléseinek elkerülése érdekében. A felső keretet a rács egyszerű tisztításához tervezték. Vastagság: 40 mm. Méretek (hossz és magasság) az ügyfél igényei szerint.

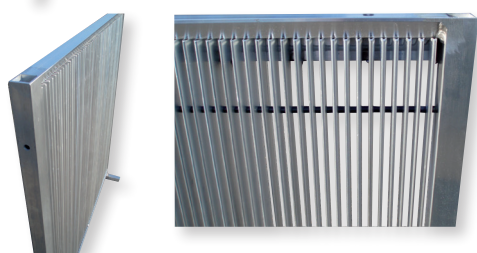

Icon	Icon (mm)	Icon	Icon (mm)	Icon	Icon (mm)
J020004	4	J020010	10	J020016	16
J020006	6	J020012	12	J020018	18
J020008	8	J020014	14	J020020	20

☞ fogli forati pagina 151 / perforated sheets page 151 / perforált lapok 151. oldal

☞ tessuto nylon-poliestere e maglia metallica pagina 100 / nylon-polyester fabric & metallic net page 100 / nylon-poliészter szövet és fém háló 100 oldal

☞ monaci di cemento e pesca pagina 190 / monks & fishing grounds page 190 / beton szerzetesek és halászat 190. oldal



Scatola di risciacquo & Tabella di ordinamento

Serbatoio FRP o HDPE (J005960) e telaio inossidabile.

Rinsing box & Sorting table

FRP or HDPE (J005960) tank and stainless frame.

Öblítő doboz és válogató asztal

FRP vagy HDPE (J005960) tartály és rozsdamentes keret.

Icon	Icon (mm)	Icon (mm)	Y (kg)
Scatola di risciacquo / Rinsing box / Öblítő doboz			
J005950	2" / 160 mm	800 × 600 × 500	16
J005960	50 mm	980 × 550 × 825	11
Tabella di ordinamento / Sorting table / Válogató asztal			
J006000	2 × 300 mm	1900 × 900 × 270	16
J006001	1 × 300 mm	3640 × 870 × 360	30